

**ME480系列 Series**
**◆产品应用/products applications**

- 三相四线电源滤波器
- 共模增强型双节滤波器，泄露电流低
- 对共模干扰和差模干扰具有优异的抑制特性
- 适用于逆变电源、变频、伺服、机床设备，数据处理系统、电信系统、工业控制系统和医用设备等干扰较为严重的场合

- Three-phase four-wire power filter
- Common mode enhanced double section filter, low leakage current, excellent suppression characteristics for common mode and differential mode interference
- Suitable for inverter power supply, frequency conversion, servo, machine tool equipment, etc. where the interference is serious

**◆技术参数/Specification**

最高工作电压 Maximum operating voltage (VAC)	工作频率 Operating frequency Hz	试验电压 Hipot test voltage			工作温度 Operating temperature	绝缘电阻 Minimum insulation resistance
		PN-E(VDC)	P-P(VDC)	P-N(VDC)		
520	50/60	2700	2250	1760	-25~+85℃	>200M @500VDC

产品型号 FILTER	端接方式 Connections	额定电流 Current rating (@40℃) A	外形尺寸 Housing	电路参数 Components
				Cy(nF)
ME480-10	/M	10	M2	4.7
ME480-20	/M	20	M2	4.7
ME480-30	/M	30	M5	10
ME480-50	/M	50	M10	10
ME480-75	/M	75	M12	47
ME480-100	/M	100	M12	100
ME480-150	/M	150	M15	220
ME480-200	/M	200	M15	470

**◆ 插入损耗/Insertion loss in dB**

CM 电流 Current rating	In 50/50Ω System Frequency (MHz)						
	0.1	0.15	0.5	1.0	5.0	10	30
10A	30	40	71	85	70	65	42
20A	23	33	70	80	71	65	60
30A	18	30	65	80	74	69	61
50A	12	19	60	78	72	68	65
75A	12	19	60	78	72	68	65
100A	10	15	35	68	70	64	58
150A	11	16	36	68	70	62	50
200A	8	14	35	70	70	60	46

DM 电流 Current rating	In 50/50Ω System Frequency (MHz)						
	0.1	0.15	0.5	1.0	5.0	10	30
10A	25	25	52	75	72	71	68
20A	22	25	50	70	72	71	68
30A	25	22	58	76	74	72	67
50A	28	19	60	78	72	70	65
75A	28	19	60	78	72	70	65
100A	10	30	71	77	70	64	62
150A	9	28	70	74	66	62	52
200A	8	26	67	72	64	61	52

◆ 电路原理图/Circuit Diagram

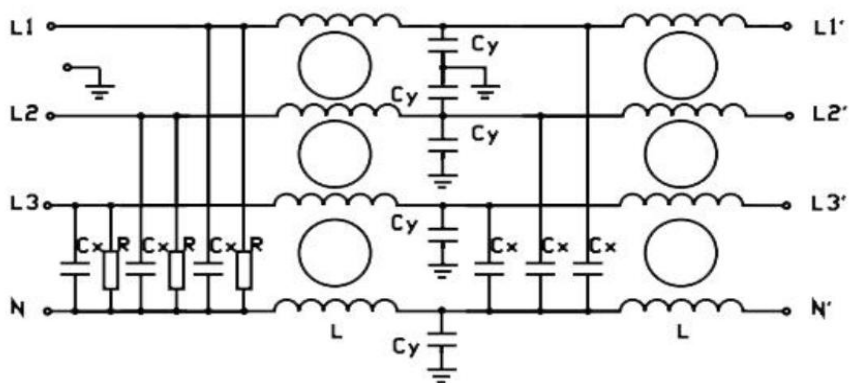

◆ 外型尺寸/Housing and dimensions: (mm)

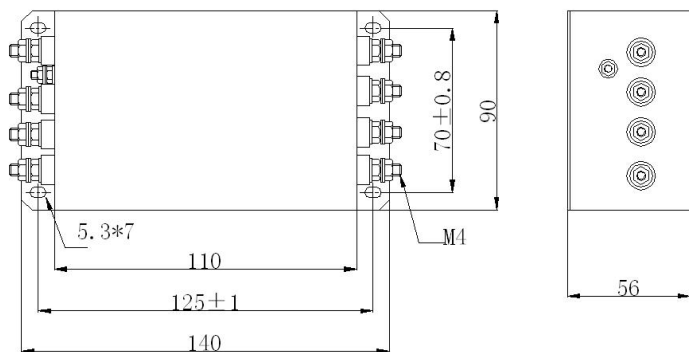

M2

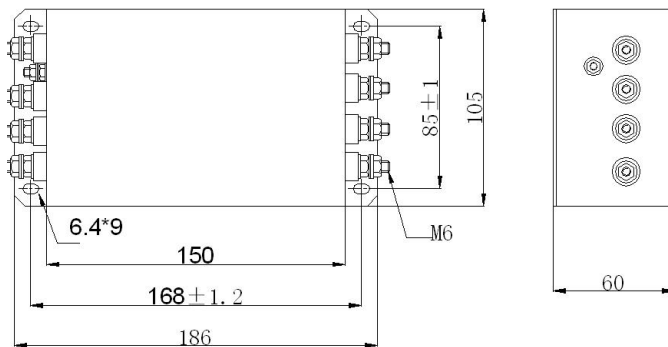

M5

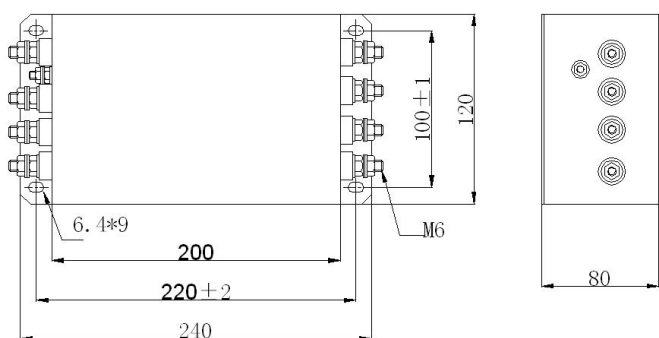

M10

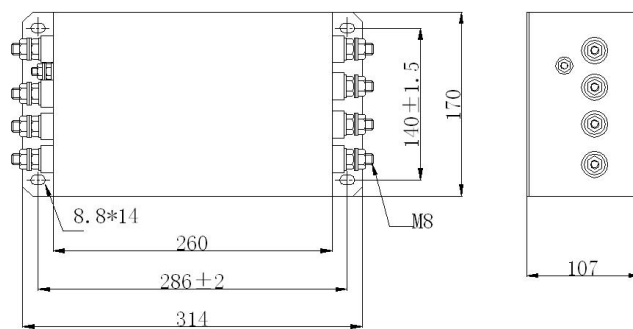

M12

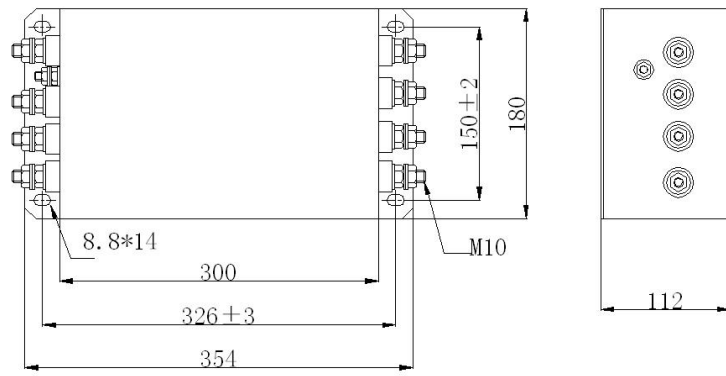

M15